

32" 3D 4K Medical Display

FM-E3204DGC



- High brightness level.
- Enable and select the best 3D format via the OSD interface.
- Fast detection of MIS camera system video.

3D Technology for the OR

Using specialized imaging systems, 3D visualization allows medical professionals to see spatial relationships and more life-like depth perception during a procedure. FM-E3204DGC monitors deliver super-sharp images using both 2D and 3D video sources. The clarity and color of 4K UHD brings out the best in all types of surgical images.

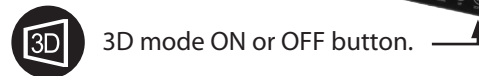
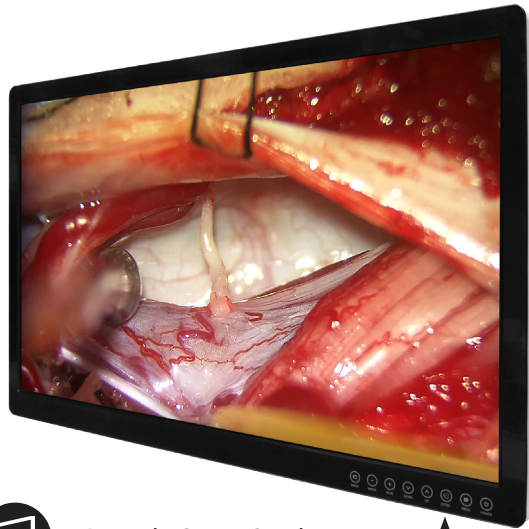

Use the OSD interface to select 2D or 3D mode, and to adjust 3D settings. Multi-window layouts can also be selected using the OSD interface.



3D eyewear that brings out the best in 3D technology is provided with each display monitor.



The technology designed into FM-E3204DGC produces superior color, sharpness, and functionality in clinical environments. Set-up and connections are simple. FSN monitors are well known for their fast detection of compatible video signals.

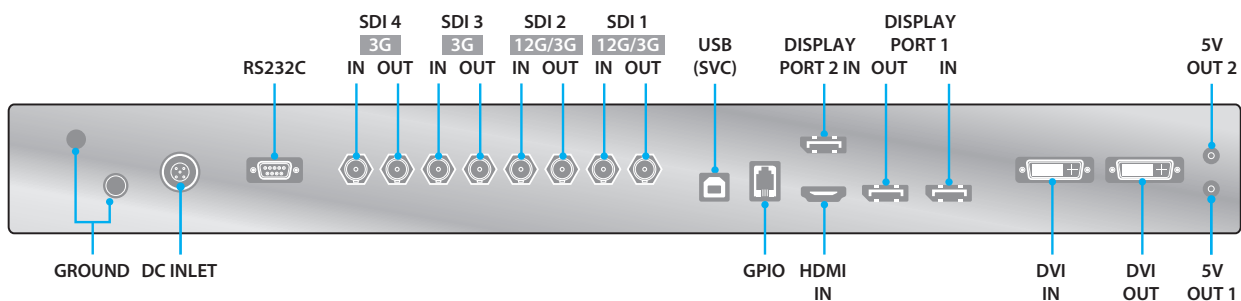

www.fsnmed.com

Foreseeson Custom Displays, Inc.
2210 E. Winston Road
Anaheim, CA 92806 USA
Tel: 714-300-0540
Fax: 714-300-0546

Latin America
Aventura, FL 33180 USA
Tel: 714-507-3855

Foreseeson Korea
404B, PangyoInnovalley B
253 Pangyo-ro
Bundang-gu Seongnam-si
Gyeonggi-do, Korea 463-400
Tel: +82-31-8018-0780
Fax: +82-31-8018-0786

Foreseeson GmbH
Industriestrasse 38a
63150 Heusenstamm, Germany
Tel: +49 6104 64398 0
Fax: +49 6104 64398 11

Foreseeson UK Ltd.
1 Wolsey Road
East Molesay
Surrey
KT8 9EL
United Kingdom
Tel: +44 (0) 208 546 1047

Foreseeson (Shanghai)
Medical Equipment Co., Ltd.
Room 307, 3F
No. 56, 461 Hongcao Road
Caohejing Development District
Xuhui, Shanghai 200233
Tel: 86-21-6113-4188

32" 3D 4K Medical Display

FM-E3204DGC



Specifications

General Features

Item	Description
Panel	32 inch TFT LCD (LED)
Resolution	3840 x 2160 pixels
Aspect Ratio	16 : 9
Active Area	708.48 (H)mm x 398.82 (V)mm
Pixel Pitch (mm)	0.1845 x 0.1845
Response Time (typical)	8 ms (rise time)
Number of Colors	1.07 Billion
3D Type	Side-by-side, line-by-line, top bottom, SDI level B-DS, SDI dual input. 3D is enabled or disabled in OSD.
Brightness (typical)	(2D) 500 cd/m ² (3D) 200 cd/m ²
Gamut	BT.709 and BT.2020 compatible
Contrast Ratio (typical)	(2D) 1250 : 1 (3D) 500 : 1
Surface Treatment	Anti-glare
Viewing Angle (CR>10)	(2D) R/L 178°, U/D 178° (3D) U/D 6°

Item	Description
Input Signal	1 x HDMI 2.0 (HDCP 2.2) 2 x DP 1.2 (SST) 1 x DVI (single link, compatible HDMI 1.4 and HDCP 1.4) 4 x SDI (3G), 2 x SDI (12G)
Output Signal	1 x DP 1.2 (SST) 1 x DVI (single link) 4 x SDI (3G), 2 x SDI (12G)
Power Supply	AC/DC Adaptor (AC 100~240V, DC 24V/6.6A)
Power Consumption	135W max
Accessories Included	User manual, AC-DC adaptor, AC power cord, DP cable, HDMI cable, DVI-D cable, SDI cable, 3D glasses, Screw BH M4 x 14 - 4 pcs.
Latency	9 ms
Unit Dimension	760(W) x 465(H) x 71.4(D) mm 29.92(W) x 18.31(H) x 2.81(D) inch
Package Dimension	914.4(W) x 749.3(H) x 234.95(D) mm 36(W) x 29.5(H) x 9.25(D) inch
Weight	10.7 kg, 23.59 lbs. (monitor with cover) 16.50 kg, 36.38 lbs. (shipping package)
Certifications	ANSI/AAMI ES60601-1 (UL60601-1), CAN/CSA C22.2 No. 60601-1, FCC Class B, EN60601-1, EN60601-1-2, CE, MDR(EU) 2017/745 Class I Medical Device

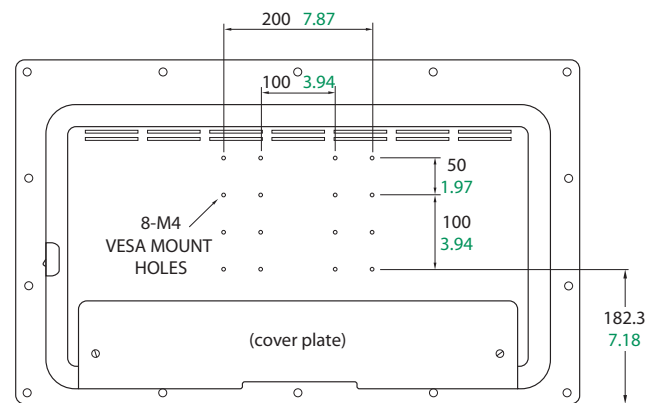
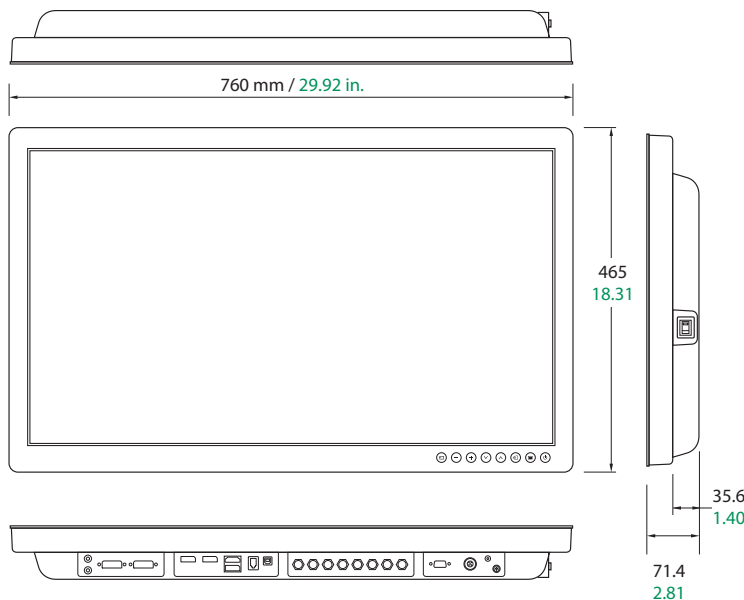

FSN Medical Technologies products meet EU RoHS Directive 2011/65/EU+2015/863/EU and Registration, Evaluation, Authorisation and Restriction of Chemicals (REACH) obligations. FSN manages the information flow as required by regulations.

Specifications are subject to change with or without notice. Doc. # FSN2042 Rev. 11/21

www.fsnmed.com

Foreseeson Custom Displays, Inc.

2210 E. Winston Road
Anaheim, CA 92806 USA
Tel: 714-300-0540
Fax: 714-300-0546

Latin America
Aventura, FL 33180 USA
Tel: 714-507-3855

Foreseeson Korea

404B, Pangyo-innovalley B
253 Pangyo-ro
Bundang-gu Seongnam-si
Gyeonggi-do, Korea 463-400
Tel: +82-31-8018-0780
Fax: +82-31-8018-0786

Foreseeson GmbH

Industriestrasse 38a
63150 Heusenstamm, Germany
Tel: +49 6104 64398 0
Fax: +49 6104 64398 11

Foreseeson UK Ltd.

1 Wolsey Road
East Molesey
Surrey
KT8 9EL
United Kingdom
Tel: +44 (0) 208 546 1047

Foreseeson (Shanghai)

Medical Equipment Co., Ltd.
Room 307, 3F
No. 56, 461 Hongcao Road
Caohejing Development District
Xuhui, Shanghai 200233
Tel: 86-21-6113-4188