

21.5" HD LED Medical Display

FS-E2101D



FSN Medical Technologies has solutions for high definition displaying of medical video signals. Our products are engineered and built for compatibility with specialized surgical and diagnostic equipment used in operating rooms, emergency rooms, and procedural facilities.

Crystal Clear High Definition Images

FS-E2101D is equipped to handle tasks in the demanding OR environment. It features rapid video signal detection, image pan, zoom, freeze, picture-in-picture, all in a fanless - sterile field compatible enclosure. This 21.5 inch HD monitor offers exceptional value. The size is ideal for limited spaces that still require monitor maneuverability.



User Friendly

FS-E2101D features an intuitive, full-featured on screen menu for image and layout settings. Multi-modality options let doctors view two images at the same time. The rounded monitor housing corners help protect



OR personnel from accidental bumping injuries. Its lightweight design is ideal for boom or spring-arm mounting, and the front surface is edge-to-edge glass for fast, easy cleaning.

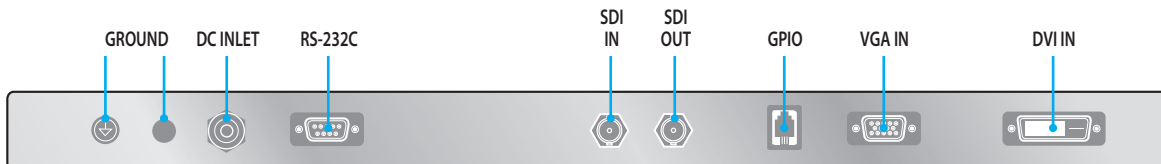
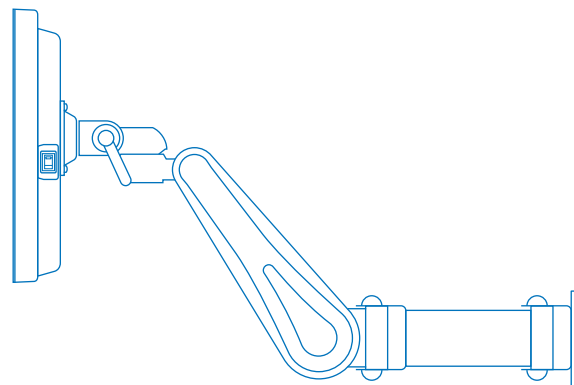
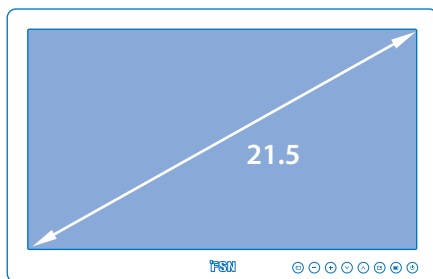

www.fsnmed.com

Foreseeson Custom Displays, Inc.

2210 E. Winston Road
Anaheim, CA 92806 USA
Tel: 714-300-0540
Fax: 714-300-0546

Latin America
Aventura, FL 33180 USA
Tel: 714-507-3855

Foreseeson Korea

404B, PangyoInnovalley B
253 Pangyo-ro
Bundang-gu Seongnam-si
Gyeonggi-do, Korea 463-400
Tel: +82-31-8018-0780
Fax: +82-31-8018-0786

Foreseeson GmbH

Industriestrasse 38a
63150 Heusenstamm, Germany
Tel: +49 6104 64398 0
Fax: +49 6104 64398 11

Foreseeson UK Ltd.

1 Wolsey Road
East Molesey
Surrey
KT8 9EL
United Kingdom
Tel: +44 (0) 208 546 1047

Foreseeson (Shanghai) Medical Equipment Co., Ltd.

Room 307, 3F
No. 56, 461 Hongcao Road
Caohejing Development District
Xuhui, Shanghai 200233
Tel: 86-21-6113-4188

21.5" HD LED Medical Display

FS-E2101D



Specifications

General Features

| Item | Description |
|--------------------------|--|
| Panel | 21.5 inch TFT LCD (LED) |
| Resolution | 1920 x 1080 pixel |
| Aspect Ratio | 16 : 9 |
| Active Area | 476.06(H)mm x 267.79(V)mm |
| Pixel Pitch (mm) | 0.2479 x 0.2479 |
| Response Time (typical) | 22 ms (rise and fall) |
| Number of Colors | 16.7 million |
| Brightness (typical) | 400 cd/m ² |
| Contrast Ratio (typical) | 1000 : 1 |
| Surface Treatment | Double side AR & AF |
| Viewing Angle (CR>10) | R/L 178°, U/D 178° |
| Input Signal | 1 x DVI-D (single link) 1 x VGA 1 x SDI (SD/HD/3G) |
| Output Signal | 1 x SDI (SD/HD/3G) |
| Power Supply | AC/DC Adaptor (AC 100~240V, DC 12V 5A) |
| Power Consumption | 40W max |

| Item | Description |
|----------------------|---|
| Accessories Included | User manual, AC-DC adaptor, AC power cord, DVI-D to HDMI cable, Screw BH M4 x 14 |
| Unit Dimension | 527.9(W) x 334.5(H) x 57.9(D) mm 20.78(W) x 13.17(H) x 2.28(D) inch |
| Package Dimension | 670(W) x 580(H) x 163(D) mm 26.38(W) x 22.83(H) x 6.41(D) inch |
| IP Rating | IP33 - overall, IP44 - front side only |
| IK Rating | IK06 with 5H AR glass |
| Weight | 5.6 kg, 12.35 lbs. (monitor) 8.36 kg, 18.43 lbs. (shipping package) |
| Certifications | ANSI/AAMI ES60601-1(UL60601-1), CAN/CSA C22.2 No. 60601-1, FCC Class B, EN60601-1, EN60601-1-2, CE, MDR(EU) 2017/745 Class I Medical Device |

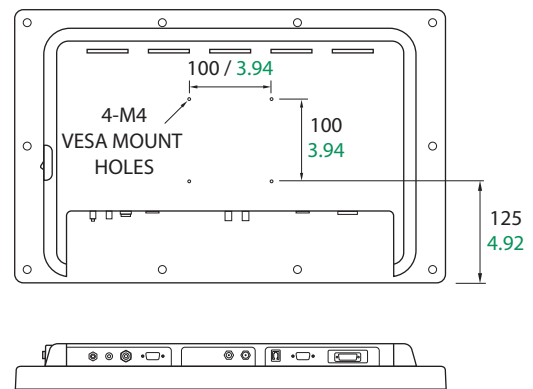
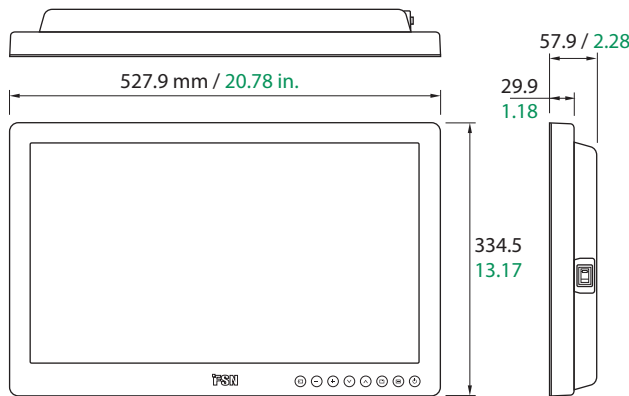

FSN Medical Technologies products meet EU RoHS Directive 2011/65/EU+2015/863/EU and Registration, Evaluation, Authorisation and Restriction of Chemicals (REACH) obligations. FSN manages the information flow as required by regulations.

Specifications are subject to change with or without notice. Doc.# FSN2010 Rev. 11/21

www.fsnmed.com

Foreseeson Custom Displays, Inc.

2210 E. Winston Road
Anaheim, CA 92806 USA
Tel: 714-300-0540
Fax: 714-300-0546

Latin America
Aventura, FL 33180 USA
Tel: 714-507-3855

Foreseeson Korea

404B, PangyoInnovallley B
253 Pangyo-ro
Bundang-gu Seongnam-si
Gyeonggi-do, Korea 463-400
Tel: +82-31-8018-0780
Fax: +82-31-8018-0786

Foreseeson GmbH

Industriestrasse 38a
63150 Heusenstamm, Germany
Tel: +49 6104 64398 0
Fax: +49 6104 64398 11

Foreseeson UK Ltd.

1 Wolsey Road
East Molesey
Surrey
KT8 9EL
United Kingdom
Tel: +44 (0) 208 546 1047

Foreseeson (Shanghai) Medical Equipment Co., Ltd.

Room 307, 3F
No. 56, 461 Hongcao Road
Caohejing Development District
Xuhui, Shanghai 200233
Tel: 86-21-6113-4188